

Templaco Tools, Inc. Models: BJ-100, BJ-101 & BJ-102

Bore Master Jr. Instructions

Ph (800) 578-9677 www.templaco.com

• 1. Position Fixture On Door

Loosen the small wing-nut and back off the black plastic coated thumb screw several turns counter clockwise.

With both bits installed into the fixture and fully retracted, slide the fixture onto the door. Tighten the large handle until both jaws of the fixture just contact the door surface then back off the large handle one turn. Screw the black thumb screw in until it stops, tighten the small wing-nut. Tighten the large handle firmly but don't over tighten, it isn't necessary. Look to see if both jaws of the fixture are parallel and in Full Contact on both sides of the door. If they are not, then loosen the large handle and adjust the black thumb screw to achieve this parallel alignment. Repeat if necessary to get this alignment.

Note: Backset Position: As shown below, fixture is set for a 2-3/4" backset. For 2-3/8" backset locks, remove the backset screws from the stored position (as shown) and install them in the fixture in the contact position. Tip: The screws never leave the fixture.



• 2. Bore Lock & Latch Holes

Install the Quick-Release Adapter into your drill motor. Pull back on the chrome slide lock of the adaptor and insert it onto the large bit that is installed in the Bore Master Fixture. Bore the large lock bore through the door (cross bore). Withdraw the bit and remove the adaptor from the bit by pulling on the chrome slide lock. Install the adaptor onto the 1" Bit and bore the Latch Bore hole (edge bore). It may be necessary to bore the latch hole in several steps, withdrawing the bit to remove sawdust from the cutting head, this is a normal occurrence, don't force the bit, let it do the work.

Tip: Keep your bits sharp, use a slower speed drill motor.

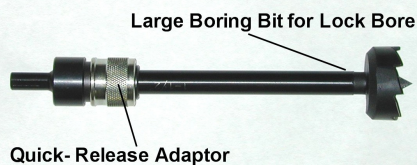

• 3. Latch Plate Installation

After boring the 1" hole for the latch into the door edge, insert the pilot end of the **Latch Mortiser** into the hole. Align vertically with the door edge then strike with your hammer to outline the area to be (mortised) chiseled out with your chisel.

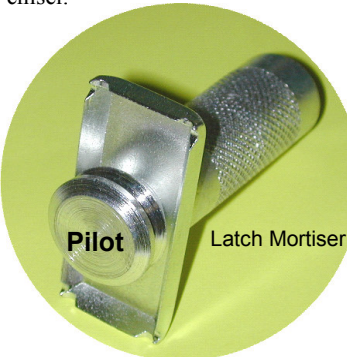

• 4. Strike Plate Installation

After the door has been hung into the jamb opening and both lock holes bored into the door, close the door onto the door stop and mark the center point of the latch bore on the jamb. You will do this by inserting the aluminum center marker supplied in the kit into the large lock hole (see photos) and closing the door. Use firm pressure to make a visible mark with the point of the center marker onto the jamb. This is your starting point for the 1" hole that you will drill into the jamb. Insert the pilot of the **Strike Mortiser** into the 1" hole in the jamb face then strike it with your hammer to outline the area to be (mortised) chiseled out with your chisel.

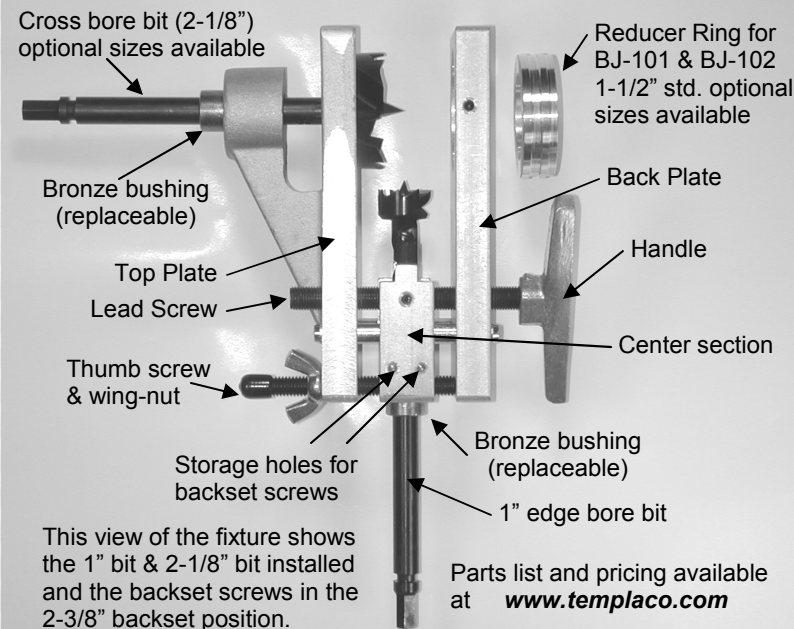

Information & Tips:

Keep the boring bits sharp, don't push harder to make a dull bit cut. This will cause wear on the bronze bushings and damage or break the bit and damage the back plate on the fixture. We have Carbide Tipped spur bits available.

Use the Quick-Release Adaptor to drive the boring bits, Don't chuck them directly into the drill motor.

A drop or two of light oil on the bronze bushings after every five doors will extend the life of the bushings and the fixture. Use a slow speed drill motor.

Need Help? Call us 800 578-9677
Need Parts? www.templaco.com